

LAB 11.2

Using Slope Angles

Name(s) _____

■ **Equipment:** The tables from Lab 11.1, CircleTrig geoboard, CircleTrig geoboard paper

1. How tall is the flagpole?

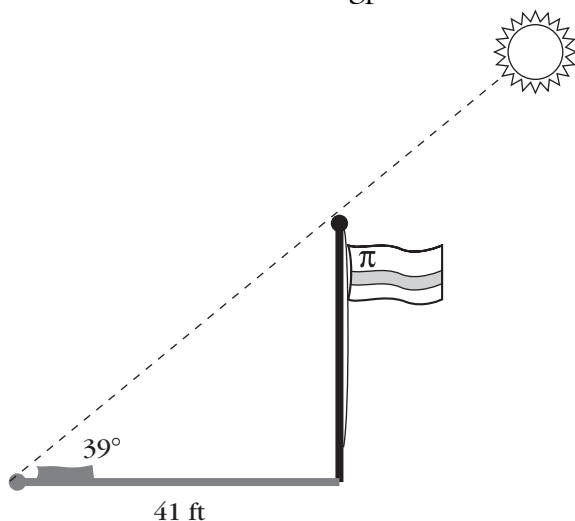

2. How far is the boat from the edge of the cliff?

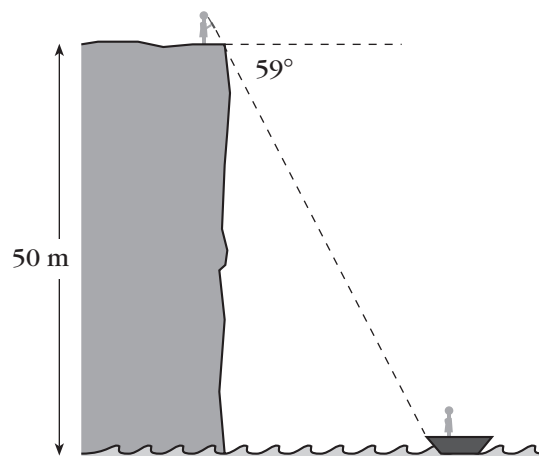

For the remaining problems, make your own sketches on a separate sheet of paper.

- Looking down at a boat from a 30-m-high lighthouse, an observer measures an angle of 15° below the horizontal.
 - Sketch this.
 - How far is the boat from the base of the lighthouse?
- A ski lift rises 200 meters for a run of 250 meters. What angle does it make with the horizontal?
- At a certain time of day, a 33-ft flagpole casts a 55-ft shadow. What is the angle made by the sun's rays with the horizontal?
- The banister of a straight staircase makes an angle of 39° with the horizontal. The stairs connect two floors that are 10 feet apart.
 - How much horizontal space does the staircase take?
 - If steps are 8 inches high, how wide are they?
- You stand on a cliff, looking down at a town in the distance. Using a map, you find that the town is 1.2 km away. The angle your line of vision makes with the horizontal is 11° . How high is the cliff?
- A right triangle has a 15° angle and a short leg of 18 units. How long is the long leg?
- A right triangle has a 75° angle and a short leg of 18 units. How long is the long leg?

LAB 11.2

Using Slope Angles (continued)

Name(s) _____

Discussion

- A. The problems in this lab have been rigged to use only angles and slopes that you included in the tables. The figure suggests a method for finding the slopes and angles in other cases by using a rubber band *between* pegs on the CircleTrig geoboard or a ruler on the paper geoboard. Explain the technique.
- B. Find the angles for slopes of 10, 25, 100. What happens as the slope gets bigger and bigger?

